

# TECHNICAL DATA

**LIBERTY HARDWARE®**  
MANUFACTURING CORPORATION

**A Masco Company**

140 Business Park Drive • Winston-Salem, NC 27107  
800.542.3789 • T 336.769.4077 • F 336.769.1839  
www.libertyhardware.com

## TWIN TOWEL BAR 2770 Series

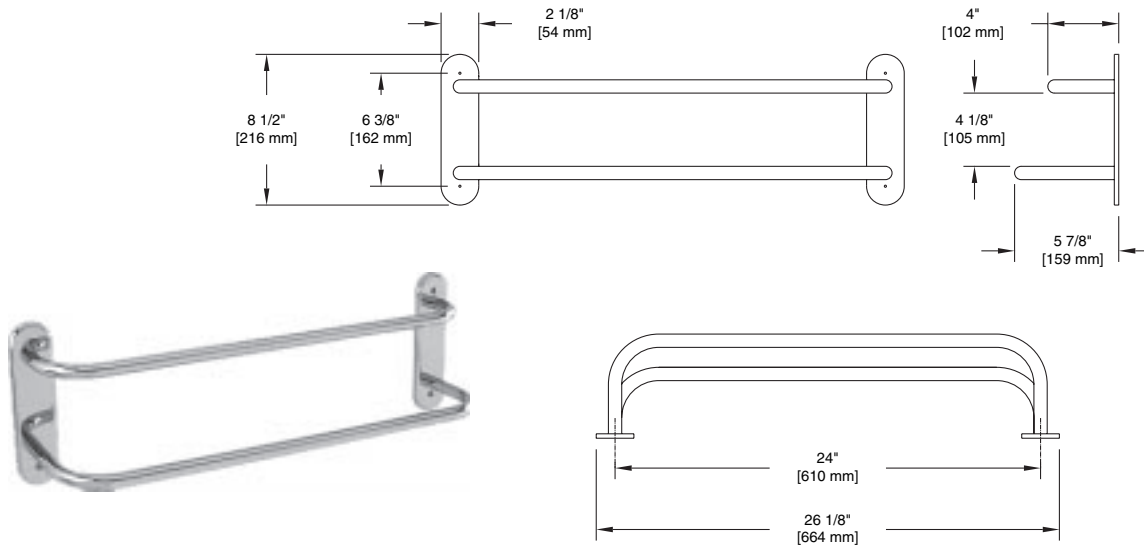

**MATERIALS:** Wall Flange- 17 gauge stamped brass  
Shelf Tubing - .035 (20 gauge) 3/4" O.D. brass tubing

Towel bar tubing is attached to wall flanges with knurled brass bushings, brass washers and #1/4 - 20 x 1/2" zinc plated steel machine screws.

**INSTALLATION:** Install top and bottom towel bars on wall flanges with 4-1 1/4" machine screws through lock washers and support plates. Mount assembled twin towel bar with 4- #9 x 1 1/2" flathead nickel plated steel screws provided or 4- 3/16" x 3" zinc plated steel toggle bolts provided.

Wood blocking is preferable behind all wall surfaces. If wood blocking is not available, the following optional fasteners are suggested:

Tile/Masonry - Plastic or lead anchors  
Plaster/Drywall - Toggle bolts

**SPECIFICATION:** Surface mounted twin towel bar shall be model \_\_\_\_\_ (fill in model number)  
by Liberty Hardware Manufacturing Corporation.