

D807 Series

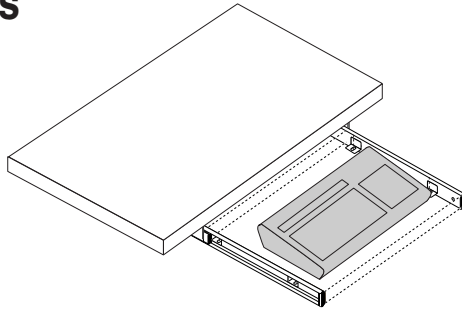

SPECIFICATIONS

Outboard mounting detail "A"

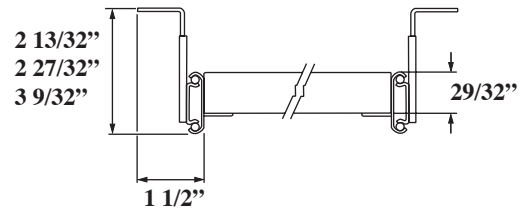

A

Inboard mounting detail "B"

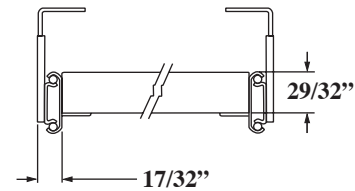

B

Keyboard Slides

Before You Begin

- Read the Do-It-Yourself Installation Instructions completely before starting.
- Make sure all parts are included.

Parts List

- 1 right-hand bottom-mounted drawer slide
- 1 left-hand bottom-mounted drawer slide
- 4 L-shaped mounting brackets
- 4 M4 x 5 pan head machine screws
- 14 #6 x 5/8" pan head wood screws (2 extras provided)

Recommended Tools

- #2 Phillips Head Screwdriver
- Pencil or Scribe
- Tape measure or ruler

Data

- 50 lb. maximum holding capacity per pair
- Available in lengths of 16"

Specifications

- L-shaped mounting bracket is reversible for outboard mounting (detail "A") or inboard mounting (detail "B").
- Outboard mounting requires a mounting space that is 3" wider than keyboard shelf.
- Inboard mounting requires a mounting space that is 1-1/16" wider than keyboard shelf.
- Maximum suggested keyboard thickness is 2-1/4" based on 3/4" thick shelving material.
- Overall height has three adjustable settings: 2-13/32", 2-27/32", 3-9/32".

1. Installing L-shaped mounting brackets to drawer slides

Place brackets for ideal height and direction position. Fasten with M4 x 5 pan head machine screws.

2. Installing keyboard shelf onto drawer slides

Align the shelf 1/16" shorter than the slide plastic protector. Fasten shelf with (4) #6 x 5/8 pan head wood screws.

3. Installing drawer slides to underside of table

With the drawer slides fully closed, mark the bracket locations so shelf is 1/4" - 1/2" shorter than the front edge of the table. Fasten shelf with (8) #6 x 5/8 pan head wood screws.

1

L-shaped mounting bracket

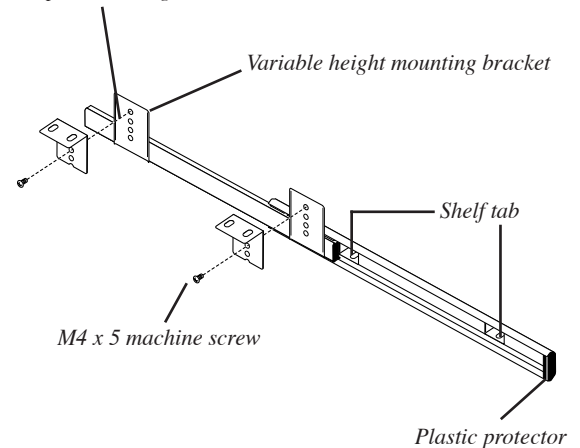

2 3

